

Data Sheet



DCW 2004 B SHF / Art. Nr.: 1026



The remote powering coupler DCW 2004 B allows a comfortable remote coupling of our SUPER-AMP preamplifiers via the coaxial cable as well as for delayed switching of HF-linear amplifiers.

The sequential operation of the DCW 2004 B avoids reliably any damage to the preamplifier that may be caused by HF-spikes during switching. It offers 3 switching outputs in total, which have ascending delay times. So not only linear amplifiers but other devices, like transverters, can be switched on with defined times.

The DCW 2004 B is designed for the amplifiers

SP 6 (6m-band),
SP 2000 (2m-band) and
SP 7000 (70cm band).

The PTT switching input of the DCW 2004 B accepts a circuit against ground or against + 5 ... 12 V. The preamplifier and a linear amplifier (if used) can be switched on or off as required.

The HF-section of the DCW 2004 B offers a very low insertion loss and a high shielding factor.

Technical Data

Operating voltage	12 – 14 V
Frequency range	23 cm, 13 cm
max. HF- Capacity	23 cm / 100W 13 cm / 50W
Insertion loss	0.2 dB
Preamplifier voltage	0,5A max. loadable
P.T.T switching output	30 V at 0,5A max.
Relay switching outputs	30 V at 0,5A max.
- P.T.T-input	switches at < 2V
+ P.T.T-input	switches at > 5V
Dimensions	140 x 120 x 53 mm

Do not open the unit. It does not contain any parts needing maintenance. If you need help regarding technical matters, please contact our team:

technik@ssb-electronic.de

Data Sheet



DCW 2004 B SHF / Art. Nr.: 1026

Installation

After insertion of the preamplifier as close as possible to the antenna feeding point, the outdoor wiring is finished already. In the shack the end of the downleading cable has to be connected to "PREAMPLIFIER". Please note that no filters or similar devices may be inserted, as that would influence the direct voltage transfer to the preamplifier! At the socket „TRX (PA)" the HF-output of a transceiver or power amplifier can be connected. At the Sub-D socket the DC wiring has to be proceeded as described in the wiring diagrams on the subsequent page. Very long coaxial cables may hinder a safe switching of the preamplifier due to potential drop, especially at low outside temperatures. Hence we recommend not to undershoot an operating voltage of 13.8 Volt at the coupler!

Operation with a linear amplifier

For operation with a linear amplifier the DCW 2004 B SHF is equipped with a PTT-switching output, which adds the final stage with a defined delay. At the PTT switching output (point 5 of the SUB-D socket) an Open-Collector switching output is available, which can direct a max. current of 500 mA to ground. Hence it is secured that the preamplifier is switched off before any transmitting power is activated.

Important: Please make sure to disable a HF-VOX control that might be built-in to your final amplifier!

The DCW 2004 B offers three outputs in total which have ascending latency times. These switching outputs can, for example, be used for activating further relays, what may be of help for more complex systems.

Operation of the remote feeding coupler

After switching on the operating voltage, a short test of the electrical connection to the remote antenna switch is carried out. When wiring is recognized as ok, the unit is switched on using factory default settings: Preamplifier and final amplifier are activated. When switched on again, the unit will start with the settings chosen before. (Last state function) In case of a short the right LED "PreAmp" blinks quickly. However, an interruption of the line cannot be recognized!

Data Sheet



DCW 2004 B SHF / Art. Nr.: 1026

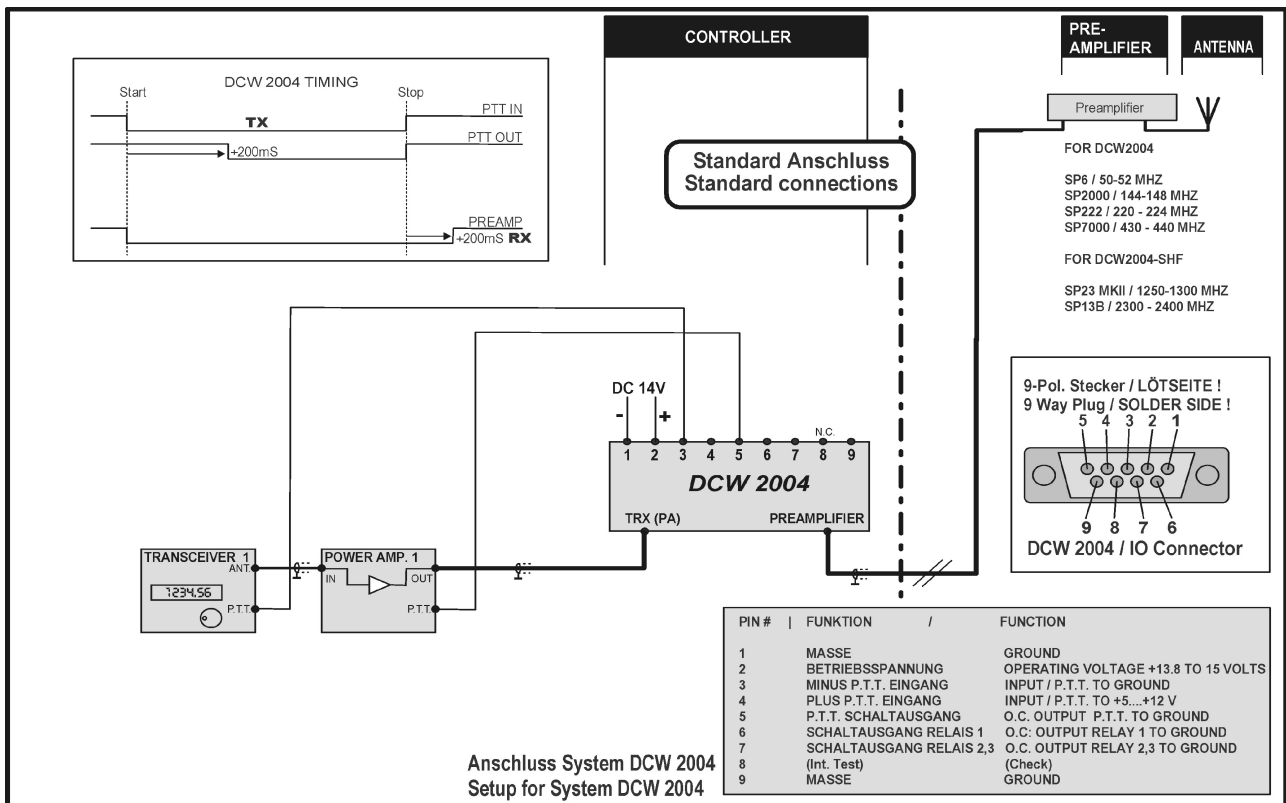
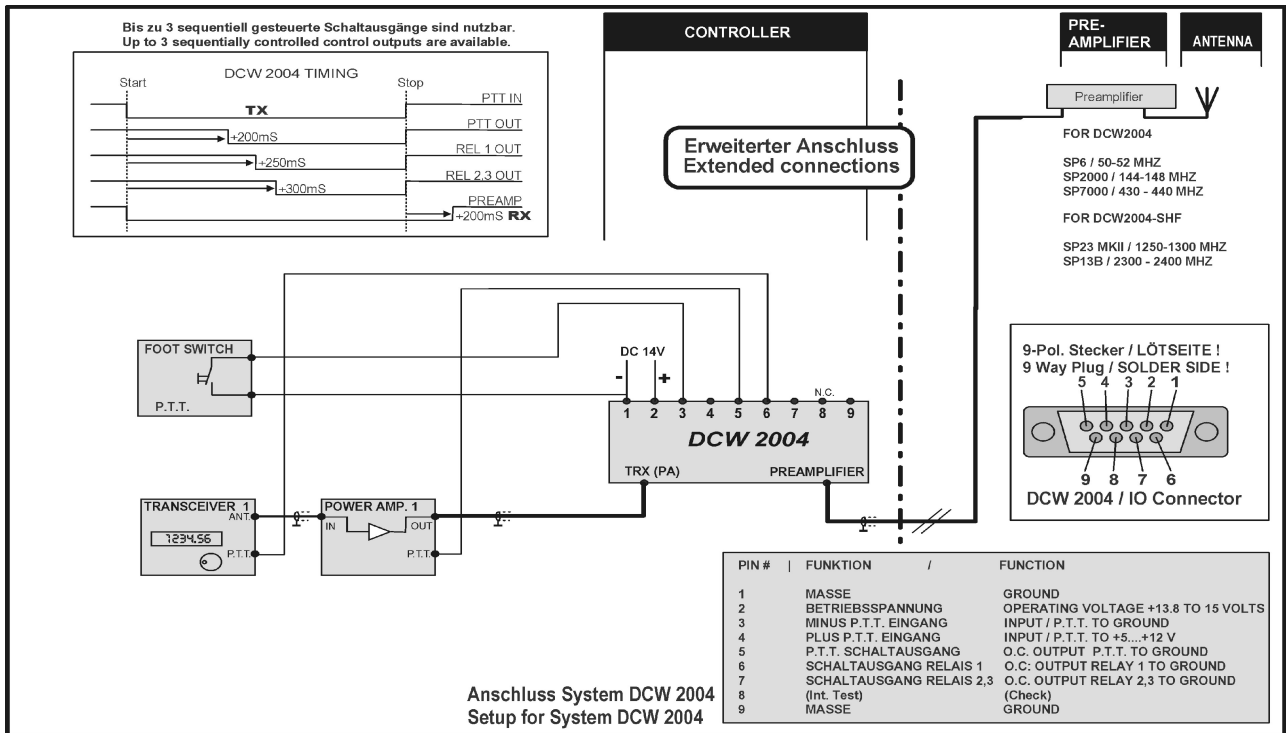

SSB-Electronic GmbH * Handwerkerstraße 19 * Iserlohn/Germany
Copyright * All rights reserved

www.ssb-electronic.de

15.07.2010

Data Sheet



DCW 2004 B SHF / Art. Nr.: 1026

Disposal of your old appliance



This product is covered by the European Community directive 2002/96/EC. 2.

All electrical and electronic products should be disposed of separately from the municipal waste stream via designated

collection facilities appointed by the government or by the local authorities. The correct disposal of your old appliance will help prevent potential negative consequences for the environment and the human health. For more detailed information about the disposal of your old appliance, please consult your city office, waste disposal service or the shop where you purchased the product. Within Germany, the above regulations are also valid for the disposal of batteries and accumulators accordingly.

Declaration of Conformity



Herewith we declare that this product complies with all relevant regulations for the product within the guidelines 73/23/EWG, 89/336/EWG and 99/5/EG of the Council:

EN 301 489-15 Electromagnetic compatibility and Radio Spectrum Matters (ERM) Electromagnetic Compatibility (EMC) standard for radio equipment and services. Part 15: specific conditions for commercially available amateur radio equipment.

EN 301 783-1 Electromagnetic compability and Radio Spectrum Matters (ERM); Land Mobile Service; commercially available amateur radio equipment. Part 1: technical characteristics and methods of measurement.

EN 301 783-2 Electromagnetic compability and amateur radio equipment. Part 2: harmonized EN covering essential requirements under article 3.2 of the R&TTE Directive.

EN 60950-1:2001 Information technology equipment – safety. Part 1: General requirements.

Manufacturer:

SSB-Electronic GmbH
Handwerkerstraße 19
58638 Iserlohn

Contact :

E-Mail: technik@ssb-electronic.de
Telephone: +49(0)2371-9590-0