

ARRAY SOLUTIONS DBS-1 BAND DECODER PCB



Instructions for installation of the DBS-1 Automatic Band Decoders.

The DBS-1 can be purchased as a single unit PCBs or with the system of two PCBs, one 19 inch panel and two toggle switches. A set of standoffs and #4 hardware is also supplied to allow you to mount the PCB to your box, or table, or the 19 inch panel if it was also purchased.

The DBS-1 **figure 2** below indicates the function of each connector terminal on the board.

Here is a checklist of how to wire your system cables.

1. Attach 12-16V DC power the power terminals by wiring it to your station supply. 500 ma-1 Amp is adequate for current.
2. Wire the toggle switch to the "Freeze" terminals, you may solder two wires to each of them. Be sure you short the wires when the switch is in the UP position. That means use the lower two terminals on the toggle switch.
3. Wire the antenna relays and the band pass filter relays, if used, to the proper + or – band output terminals. Be sure to use the system shown below for sinking or sourcing outputs.
4. Connect the radio interface cable to the cable input Jack # 6 below and your radio or LPT port.
5. If using an Icom radio select the desired baud rate. Factory setting is 9600 Baud, removed is 1200 Baud.
6. If you desire to use PC keying wire the CW keyer output as shown # 5 CW output and send to your radio key port or the SO2R Master
7. If you want to use QSK with the Yeasu radios wire to the CW Keyer output terminal block #5. The Yeasu Radio Cable will route the solid state PTT signal to a driver transistor on board and out this port. This PTT signal can drive up to .5 Amps which is much higher then the Yeasu PTT QKS signal.

Now install your panel or circuit board into its final position. If you did not buy the 19 panel then place the Freeze toggle switch where you can easily reach it.

Cable Chart DBS-1 DB-15 Pinout		
Pin	Function	
1	Binary Band "B" (2)	Pulled down, 3-5Vdc = 1.5volts MAX!
2	Binary Band "A" (1)	Pulled down, 3-5Vdc = 1.5volts MAX!
3	Binary Band "D" (8)	Pulled down, 3-5Vdc = 1.5volts MAX!
4	Binary Band "C" (4)	Pulled down, 3-5Vdc = 1.5volts MAX!
5	NC	
6	RXD Serial Input	
7	TXD Serial Output (not used)	
8	2N4401 Base (PC Keying)	
9	GND	
10	GND	
11	GND	
12	PTT Base (GND to TX)	12 volts max open circuit
13	NC	
14	2N4401 Emitter (PC Keying)	
15	2N4401 Common (PC Keying)	

Note: Use a DB-15 Plug

Cables

Yaesu	
DB-15 Pin	Yaesu DIN Pin
1	5
2	4
3	7
4	6
9	8
12	2

Icom	
DB-15 Pin	1/8" Plug
6	1/8" Plug Tip (Signal)
9	1/8" Plug Ring (GND)

PC Use a DB-25 Plug	
DB-15 Pin	DB-25 Pin
1	7
2	2
3	9
4	8
8	17
9	18
14	1
15	18

The above tables are provided for those who wish to build your own Radio cables and PC cables.

DBS-1 Fig 2

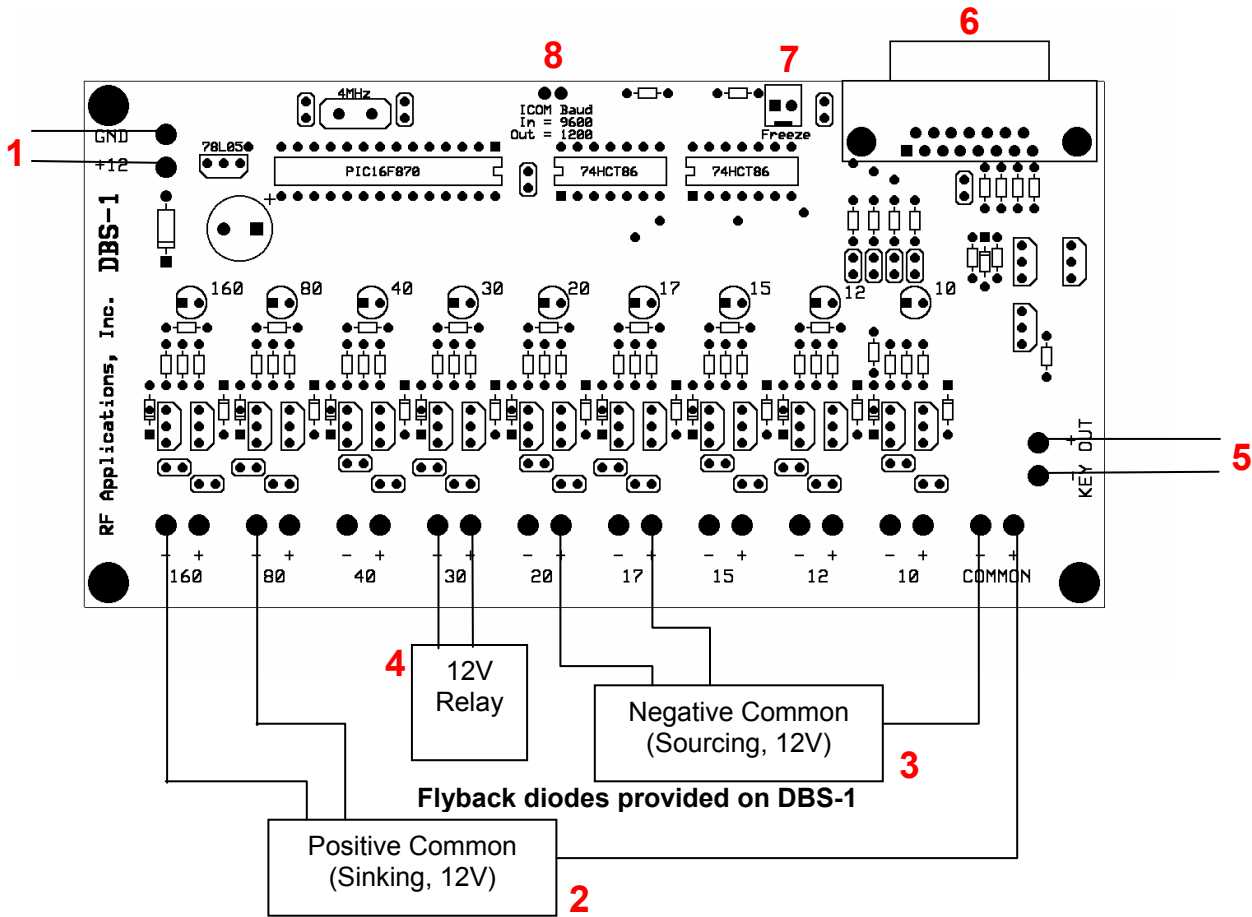

Notes

1. Use a 12 volt DC power supply. Acceptable range is 10 to 16 VDC.
2. Wire Positive Common relay arrays as shown. 300 milliamps maximum per relay. It is acceptable to parallel multiple negative outputs for tribanders, etc.
3. Wire Negative Common relay arrays as shown. 300 milliamps maximum per relay. It is acceptable to parallel multiple positive outputs for tribanders, etc.
4. Individual relays may be wired as shown. 300 milliamps maximum.
5. When using a PC, this output is used for CW keying. It is the recommended circuit used with CT, NA, etc. and is provided because the PC interface cable connects to the LPTx port on the PC. This output only functions when using the PC interface cable (but it is acceptable to add wiring from the Icom or Yaesu cables to the PC if desired).
6. Use appropriate interface cable. Cables are available for Yaesu FT-1000, PC LPTx and Icom CI-V. Connector is a DB-15F.
7. "Freeze" input. A switch may be connected across this input to freeze the DBS-1 on the last selected band. This feature can be used to force an antenna onto a band. Simply select a band, turn on the freeze input, and the unit will stay on the last band selected as new bands are selected.
8. Icom CI-V baud selection. Jumper installed is 9600 Baud, removed is 1200 baud.