

Array Solutions QSK-MASTER

External QSK T/R Switch for HF Amplifiers

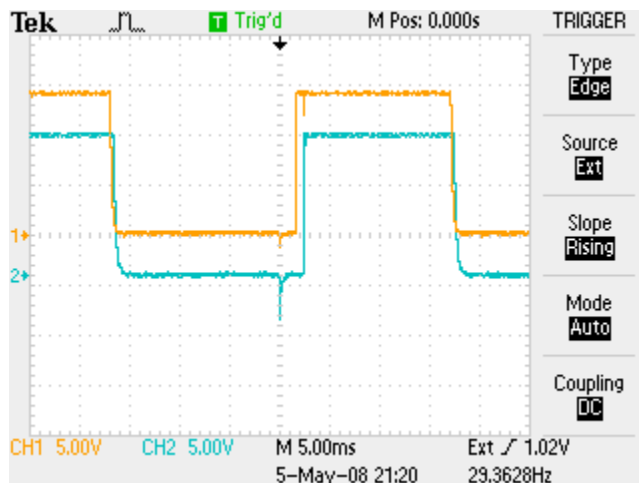

The Array Solutions QSK-MASTER is a **160-6 meter** 2500 watt external QSK switch. Internal strapping options include amplifier polarity keying sense, 120/240VAC powering, and turn-off time delay to ensure that the QSK-MASTER is compatible with **any** transceiver/amplifier combination. And the QSK-MASTER's low current keying interface means that it can be directly keyed by your transceiver without requiring a separate external transceiver/amplifier interface. For maximum reliability the QSK-MASTER is relay-based, using high-speed signal relays for transceiver, bias, and amplifier output switching. ***This means that the QSK MASTER is essentially lossless,*** so no optional fan is needed for high duty-cycle operation. ***And the QSK-MASTER cannot be damaged by any sudden high SWR event*** even when operating at maximum power. As you can see in the figure below, the relays switch in less than 5ms (typically less than 3ms) ensuring relay operation is faster than the "amp-enable-to-RF output" delay of your transceiver.



Some popular transceiver "amp-enable-to-RF output" delays are as follows:

Elecraft K3:	8ms
ICOM IC-706:	15ms
ICOM IC-7000:	10ms
Kenwood TS-480/2000:	10ms
TenTec Orion/OmniVII:	15ms
Yaesu FT-1000MP MKV:	5ms
Yaesu FT-2000:	15ms

Upper trace: Amplifier output relay
 Lower trace: Transceiver/bias relay
 Trigger: Transceiver amp-enable output
 Keying speed: 80WPM

QSK-MASTER Specifications:

RF Power capability: 2500 Watts CW/SSB/Data Modes
Frequency Range: 1.8-54 MHz
Residual SWR: Typically <1.1:1 from 1.8-30 MHz, <1.2:1 on 6-meters
Insertion Loss: < 0.1 dB
Keying Input: Selectable: Closure to ground (default), or +12V amp enable output. Less than 3ma sink (ground) or source (+12V).
Enable Delay: Less than 5ms, typically less than 3ms from amp enable control.
Disable Delay: Less than 5ms, typically less than 3ms from amp disable control.
Strappable for 10ms turn-off delay.
Power Required: 120/240VAC strappable, 120VAC default
Relay Lifetime: >100 million operations
Dimensions: 3"H x 6"W x 3.5"D
Weight: 1-1/2 pounds
Optional Cables: IC7K-1 for IC-706/718/7000 (solid-state amp key and ALC)
K480 for TS-480 (solid-state amp key and ALC)
K2K for TS-440/850/870/2000 (solid-state amp key and ALC)
FT1K for FT-1000D/MP/MKV/2000/9000 (solid-state amp key)
Other cables available on request

Connections and Strapping Options

Simply connect your transceiver, QSK-MASTER and amplifier as shown in Figure 1 below. Note that the amplifier keying input must be shorted to enable the amplifier whenever it is in the OPERATE condition. The amplifier amp-key input is typically a phono jack (RCA), or screw terminals. If it is a phono jack input, insert a shorted phono plug into the amplifier's amp-key input. For screw terminals, a simple wire jumper will suffice.

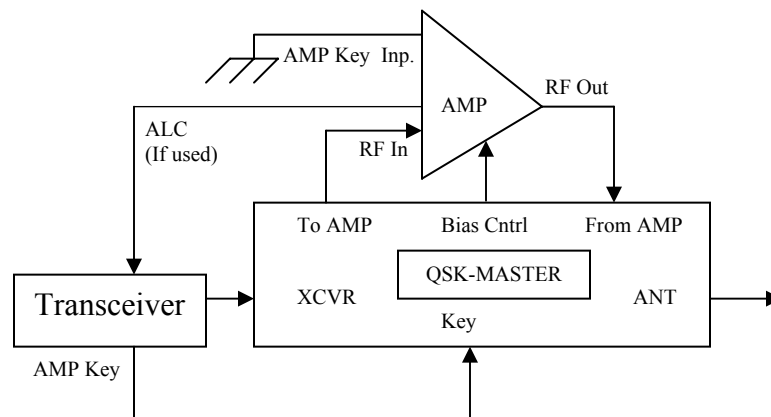

Figure 1: QSK-MASTER Interconnect Block Diagram

Note: The transceiver amp-key output must key the QSK MASTER only. The transceiver amp-key output should never directly key the amplifier. The amplifier key input must be continuously shorted for proper operation.

Refer to your transceiver's operating manual to determine the amp-enable output polarity employed. The amp-enable output of most transceivers is a relay or solid-state closure-to-ground. For optimum operation, you should always use the solid-state amp-keying interface if it is available on your transceiver, as an amp-keying relay will add switching delay. Many Yaesu transceivers only provide a solid-state amp-enable output from the BAND DATA connector. Modern Kenwood transceivers have both a relay closure-to-ground, and a solid-state output that goes to +12VDC for amplifier keying. While the Kenwood solid-state output is inverted from most other transceivers, this is supported in the QSK-MASTER through an internal strapping option.

The amp-enable output of typical transceivers is provided through a RCA (phono) connector output, so a standard RCA mono cable is all that is necessary for these transceivers. For transceivers without a solid-state RCA amp-enable output (Yaesu FT-1000/MP, IC-706/7000, Kenwood TS-480/2000, etc) you can construct your own interface cable or purchase a pre-made cable from Array Solutions.

Caution: Before opening up the QSK MASTER, always unplug the unit from the AC mains.

Amplifier Keying Sense

The QSK-MASTER default amp-keying input is an input closure-to-ground. For Kenwood or other transceivers that provide a +12VDC keying signal, the input keying enable strap J3 must be changed. Refer to Figure 2 and Figure 3 for proper strapping.

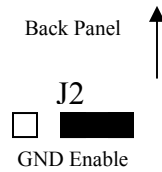

Figure 2
(Default)

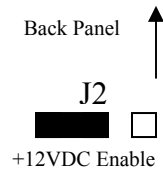

Figure 3

120/240VAC Strapping

If desired, the QSK-MASTER may be strapped for 240VAC (120VAC default). For 240VAC operation, you must change the AC connector to the desired 240VAC plug, and then change the AC input voltage strapping. Refer to Figures 4 and 5 below.

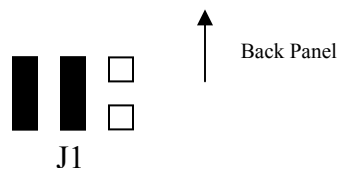

Figure 4
(120VAC Default)

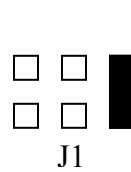

Figure 5
(240VAC)

Turn-off Delay

Most transceivers delay disabling the amplifier until the transceiver's RF output has decayed to zero. However, there are a few transceivers (notably the IC-706MKIIG and IC-7000, and the TenTec Omni V and Omni VII) which disable the amplifier *before* the RF has decayed to zero. This usually shows up as key-clicks or a high indicated SWR on your transceiver with no associated power turn-down. If one of these conditions occurs, strap JMP1 as shown in Figures 6 and 7 below. This adds 5-8ms to the turn-off delay of the QSK MASTER.

Note: Always enable JMP1 (Figure 7) when using the IC-706/MKII/MKIIG, IC-7000 and TenTec Omni V and Omni VII transceivers.



Figure 6
3ms Turn-off Delay
(Default)

Figure 7
8-10ms Turn-off Delay

Amplifier Bias Control

If desired, the QSK-MASTER has the ability to interrupt amplifier bias current when the amplifier is un-keyed. If you do not implement this feature, it is always best to switch your amplifier to STANDBY when it is not in use so as to reduce amplifier idling power dissipation. If you wish to control your amplifier bias with the QSK-MASTER, you must break the bias control voltage inside the amplifier and feed it to the BIAS stereo jack on the QSK-MASTER. One method is to mount a 1/8" stereo jack on the back of your amplifier (bias voltages to tip and ring) and then use a standard 1/8"-to-1/8" stereo cable to interface the amplifier to the QSK-MASTER. Some amplifiers have more complex bias switching, so a separate relay, controlled by the QSK MASTER's bias control line, may be required. More information on this feature can be found in the QSK MASTER FAQ section of the Array Solutions website.

Note: Many recent amplifiers include a dynamic bias control feature whereby the amplifier's resting plate current is reduced when not being driven. There is no benefit in implementing the QSK MASTER's bias control feature with these amplifiers.

Caution – Exercise extreme care when working inside an amplifier. Ensure that the amplifier is disconnected from the AC mains, and that the power supply capacitors have been discharged. Lethal voltages may be present, even when the amplifier has been turned off and unplugged!

Operation

Once the QSK-MASTER is connected to your transceiver and amplifier and the strapping is properly set as described above, all that is required for operation is to turn on the QSK-MASTER and place the amplifier into its OPERATE position. Now when you key your transceiver, the QSK-MASTER will switch the amplifier in and out of line along with your keying. It is normal to hear the clicking of the internal QSK MASTER relays.

Addendum: Using The QSK MASTER as the perfect QSK T/R Switch for Boat-Anchor Stations

If you are into nostalgia and have a classic boat-anchor station consisting of a separate transmitter and receiver, the QSK MASTER can also serve as the perfect T/R switch for your set-up. Connect your receiver to the QSK MASTER's TRANSCEIVER port, connect your transmitter to the QKS MASTER's FROM AMP port, and connect a keying line between the QSK MASTER's BIAS port and your transmitter's key input. Finally, connect a shorting PL-259 to the QSK MASTER's TO AMP port. Your key/bug/keyer keys the QSK MASTER directly. Refer to Figure 2 below:

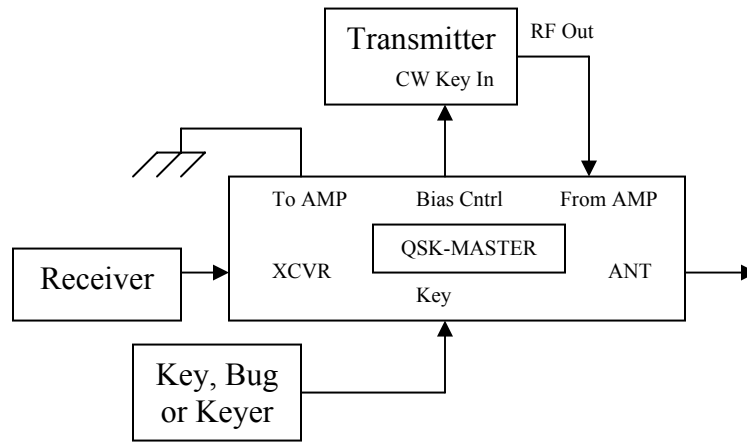

Figure 2: QSK-MASTER as Boat-Anchor T/R Switch

Operation is as follows: You key the QSK MASTER directly. The QSK MASTER instantly switches the antenna from the receiver input to the transmitter output, grounds the receiver input, and then keys the transmitter. There is no possibility of receiver