

# Array Solutions WX0B StackMatch User's Guide



Thank you for purchasing the StackMatch. It has become a standard for phasing mono-band and multi-band antennas. . The unit comes with our Life Time Warranty. If it should fail for any reason, save for an act of God, we will repair it or replace it for free. You only pay for shipping back to us.

## Controls

The StackMatch control switch box has a rotary switch and three LEDs which display the antennas selected. Think of the three LEDs as the antennas arranged on a tower with number 3 in the  $\Delta$  being at the top of the tower, number 2 in the  $\bigcirc$  being in the middle, and number 1 in the  $\square$  at the bottom of the stack. As the rotary switch is turned these LEDs will light up in a pattern which indicates which antennas are being fed power from the StackMatch. You will see these symbols also on "little towers" or lines arranged around the rotary switch knob. Just point the knob to the desired pattern and the LEDs will light to indicate in the same pattern as chosen with the switch.

These patterns represent all the combinations available for selection, including several ALL antennas selected for convenience in determining which stack arrangement works best for the propagation conditions.

The new Switch also has an OFF position at the 6:30 position. When set to OFF, the StackMatch defaults to ALL STACK position but the LED's are turned off.

The New Switch also has an AUX. position at the 2:30 position. In this position 12VDC is placed on the AUX. terminal on the terminal block inside the switch. This is meant for the SECOND FEED LINE OPTION or BIP-BOP, but there is no reason why the user could not use this to activate other functions that could be used in your station. Maybe selecting another antenna that one has wired up to bypass the StackMatch?

## Wiring the StackMatch

The StackMatch control cable should contain at least 5 wires, or 4 wires and a shield. 18-20 gauge wires will work for even very long runs since the relay currents are only 40 ma. You will also need a 2 wire 12VDC cable that you will wire to the terminal strip inside the box. The control box cover should be removed. You will find a package with the circuit board, control knob, etc. A grommet is provided in the back to push the control cable through.

Strip the insulation of the 5 wires and terminate them with small spade lugs, or simply just tin them. See the photo below for the terminal strip and its labeling.

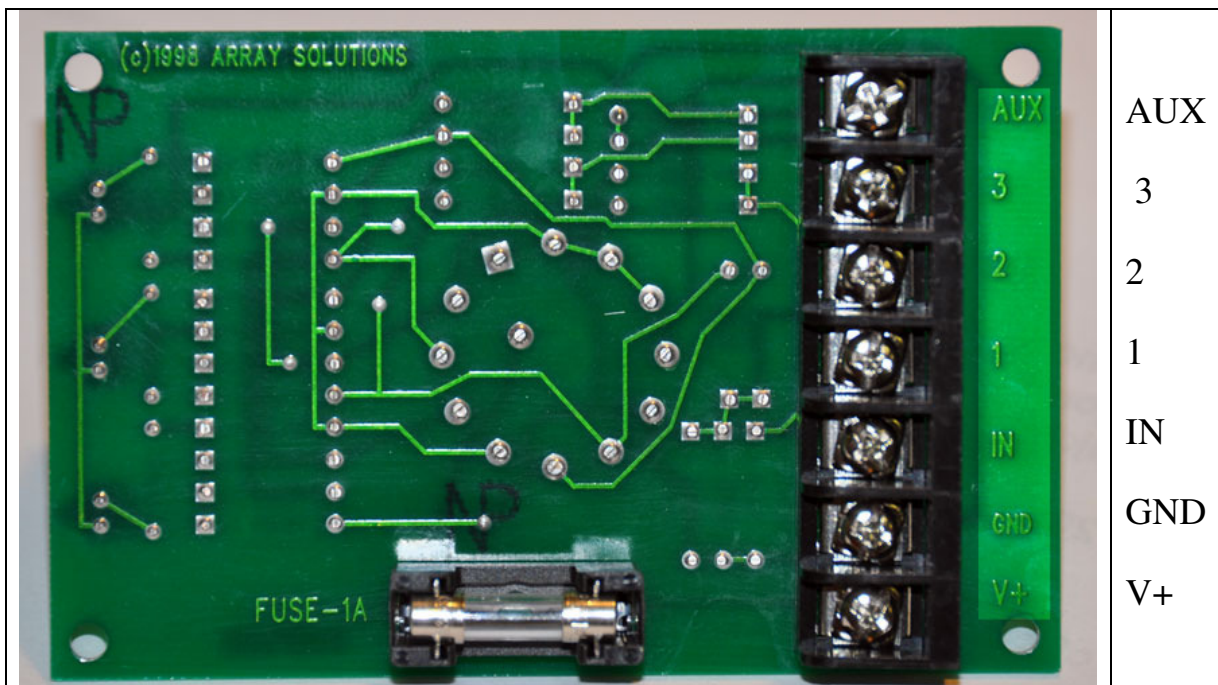

Make a chart of your wire colors so you can do the same with the StackMatch box which will be mounted on the tower or at the hub of your antenna system. Use the Ty-Wrap™ supplied to secure the cable from pulling out of the box.

Replace the circuit board and assemble the box with the hardware provided. Also attach the knob to the shaft of the rotary switch using a small screwdriver to tighten the knob to the shaft. Terminate this cable with a plug such as a Cinch Jones Plug a foot or so after it leaves the box to make it easy to disconnect the box from the cable. You may also want

to use a control cable surge arrestor such as the ICE model 347 that we sell. The StackMatch board contains MOVs on the rely board for protection from surges as well.

Use the TY-WRAP™ supplied to secure the wires from pulling out of the boxes. Replace the covers and screws.

Do the same with the StackMatch. You will find a terminal strip on its circuit board. Match the same colors to the 1,2,3,IN, and GND wires you have on your chart made earlier. If you use the AUX. function for an optional device bring this wire out of the StackMatch with a ground wire and attach them to optional function device.

## Options

**Both OUT of Phase or BOP Option** – we have introduced the first ever wideband 180 degree out of phase option. It will place one of the beams 180 degrees out of phase with the other creating some very high propagation take-off angles. It works perfectly with mono band antennas or multiband antennas such as logs, tribanders, quads, etc since it is very wide banded. 1.8-30 MHz.

**Dual Feedline Option** – with this option you may place one of the antennas on a second feedline to run to a second radio.

## Weatherproofing

**A word about weatherproofing the cable connectors and box.** There are many viable techniques to weatherproof your connectors, please use your favorite one to keep your outside connectors protected. Do not seal the tray to the lid since the ability of having the box breathe will keep it dry from condensation which normally builds up in outdoor boxes. The board is coated and suspended above the box, and all hardware is stainless steel. All relays are sealed. This unit should give you very long service.

## Power Cord Assembly and Testing the StackMatch

Build a two wire power cord which comes from your 12V DC supply in the radio shack. Attach it to the +12V and GND terminals on the terminal strip on the Switches PCB. There is a 1 amp fuse on the circuit board to protect the supply from shorts.

You can test the system in the shack to make sure you have the proper connections by turning on the 12V supply and running through the combinations while using an ohm meter to test for continuity from the feed line port to the selected proper antenna ports. You could also use dummy loads and your transceiver to verify the system. Please verify that all relays are switching correctly. If not, review your wiring and trouble shoot by testing that the 12V relay coil voltages are getting to the proper StackMatch Terminals on the terminal strip. A schematic of the switch and the StackMatch is provided to help you troubleshoot problems if they should ever occur.

## Installation

Most installations are used to phase a vertical stack of either two or three antennas. To accomplish this prepare three equal length 50 ohm coaxial cables which will reach all three of your antennas in the stack from a central position. Mount the StackMatch using a U-bolt to the tower at that central position. This is usually at the middle antenna although some prefer to mount the StackMatch at the base of the tower.

Attach the cables to each antenna, and dress them along the tower to the StackMatch box.. Attach the upper antenna to the number 3 port, the middle antenna to the number 2 port, and the lower antenna to the number 1 port. Bring a feed line from the shack to the remaining feed line port. Make sure you weatherproof your connections at the antennas and at the StackMatch.

This completes the installation.

## Operation

The SWR of the antennas should be nearly the same as they were as individual antennas. You can check them to make sure they are by selecting the individual antennas and running an SWR curve. Now chose any combination of two and three antennas and verify the curves are about the same. Typically they will move up or down only 10 KHz. If you had a 1:1 SWR with the individual antennas you should also see a 1:1 SWR with the combinations of beams. The antennas should ideally be optimized to have identical SWR curves. Taking care to do this right at the beginning will save you time and effort later. This will also assure you of equal power splits using the StackMatch.

Determining how much power gain you achieve can be modeled with the antenna programs available. You should be able to verify the stack is working by listening to DX signals and selecting various stack combinations. Remember different propagation will favor different arrival angles, and you may find the lower beam works best in some conditions vs. the stack. This is the beauty of being able to choose the takeoff angles of your signals to match the conditions during the day. Work with it several days to get a feel for what stacks can do for you.

The StackMatch can be used to select and power split to antennas which are not identical. This could be useful when you wish to beam in two different directions with antennas on the same tower or another tower or tree or whatever. Also you may wish to experiment with a vertical and a Yagi to take advantage of diversity reception and transmission. You can also feed dipoles, quads, vertical dipoles pulled away from the tower, etc. to achieve some interesting patterns.

## BIP-BOP Operation

Both-IN-Phase and Both-Out of-Phase, operation is possible for two or three multiband or mono band antennas. The reason for BOP operation is that two beams fed 180° out of phase will result in a very high angle take off lobe. This is useful for making a high stack of antennas which would have a very low take off angle main lobe work for local contacts or for E-Skip conditions where a high angle is desired. Our *180 degree wideband phase shifter option* is available for this purpose.

## POWER HANDLING, MAINTENANCE, HOT-SWITCHING, ETC.

Under normal conditions the StackMatch would not be hot switched. But as contesters know, it is inevitable that at some time either a wrong antenna will be selected or a hot switch will be made in the heat of the battle. The StackMatch has been designed with this in mind. **You will not harm the unit with an occasional mistake.**

Actually, to keep the contacts from silver oxide build-up, the manufacturer of the relays recommends that these units be hot-switched occasionally. So once a month or so, apply 100 watts of power to the unit and run through the positions to keep them clean.

Your StackMatch is rated for 3kW CW – SWR under 2:1. Higher power models are available. We have an applications note section on our website if you should need to troubleshoot your StackMatch.

---

We hope you enjoy your WX0B StackMatch. If you have any question whatsoever, please phone or email us. We are glad to assist you in whatever way we can.



Array Solutions  
2611 N Belt Line Road  
Suite # 109  
Sunnyvale, TX. 75182  
Phone 214.954.7140 Fax 214.954.7142  
E-mail: [sales@arraysolutions.com](mailto:sales@arraysolutions.com)

# Appendix A - Schematic

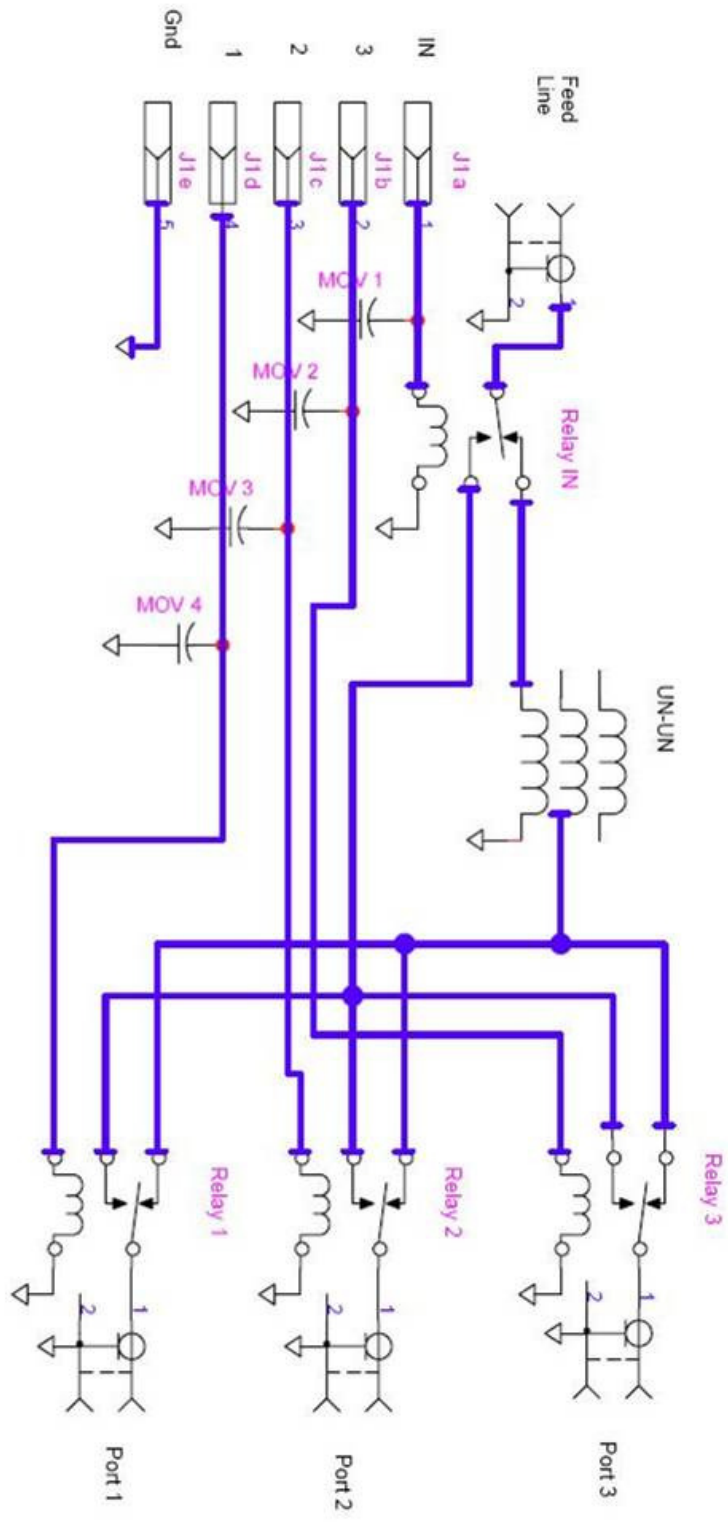

**ARRAY SOLUTIONS**  
**StackMatch 2000**

copyright 2000