

EMTRON ES-1A  
ANTENNA SELECTOR

User Manual

November 2019

**CE**



## 1. General

ES-1A is a device that allows using a Linear Power Amplifier with two antennas and two radios which are selected by front panel switches.

## 2. Description

ES-1A is contained in a metal enclosure with dimensions 196 x 116 x 85 mm.

The front panel has two toggle switches and four LED indicators.



The rear panel has six S0-239 connectors, three for the input side and three for the output side. There are also three RCA sockets for PTT connections, three RCA sockets for optional ALC connections and an Earth ground with wing nut.



The right-hand side panel has a DC power connector and two telephone jacks (RJ12), one near the front and one near the rear panel. These two RJ12 jack s are joined by a short external, removable flat cable (telephone type).

### 3. Electrical Connections

Use coaxial cable of appropriate rating for the following connections:

- ▶ Connect the linear amplifier input to the ES-1A socket marked "AMP IN".
- ▶ Connect the two radios/ transceivers (antenna output) to "Radio 1" and "Radio 2" inputs on the ES-1A.
- ▶ Connect the linear amplifier output to the ES-1A socket marked "AMP OUT" .
- ▶ Connect the two antennas (or one antenna and one dummy load) to the ES-1A outputs marked "Antenna 1" and "Antenna 2" .

Other (non-coaxial) connections:

- ▶ **PTT:** Connect the "PTT-AMP" socket of ES-1A {middle RCA} to the PTT connector on your linear amplifier. An extra cable is required for this additional connection (possibly RCA male to RCA male - not supplied).  
If one radio is used, connect its PTT cable to PTT1 or PTT2.  
If two radios are used, connect one of them to PTT1 and the other one to PTT2 {they are interchangeable}.

This connection is optional, but recommended since the ES-1A "hot switching protection" function will only work with a PTT connection

- ▶ **ALC:** If ALC is used, connect the amplifier ALC to the middle RCA socket marked "ALC AMP". Connect the radio ALC to the top and/or bottom RCA sockets marked ALC1 and ALC2 (interchangeable).
- ▶ **EARTH:** An M4 screw with wing nut on the ES-1A rear panel allows it to be earthed. This is an optional but recommended connection.
- ▶ **POWER:** Connect the supplied DC power plug into the socket on the side of the ES-1A. Connect the black(-) and red(+) wires to a 12Vdc power source. Typically, the power supply used for the radio/ transceiver can be used to also power the ES-1A. The supply voltage limits are in the 11 to 15 V range.  
The current requirement is up to 250mA. (2.5 x 5.5 mm)

**Warning:** If the power connection is made in wrong polarity the ES-1A won't be damaged, but it will not work. When the unit is not powered the amplifier input will be an open circuit and the "Radio 1" and "Radio 2" inputs are grounded. The amplifier output will be switched to "Antenna 2".

### 4. Operation

As soon as the power is connected to the ES-1A, two of the front LED indicators will turn on (there is no power ON/OFF switch).

Simply put the "IN" toggle switch in position 1 or 2 and the top (red) or bottom (green) LED will turn on. At the same time, a relay will be activated, connecting the "AMP IN" SO-239 socket to either "Radio 1" (top) or "Radio 2" (bottom) SO-239 socket, depending on the switch position .

Changing the "OUT" front panel switch between position 1 (up) and position 2 (down) will cause the red or the green indicator to turn on. At the same time the SO-239 "AMP OUT" socket is connected by internal re1Ay to "Antenna 1" or "Antenna 2" SO-239 sockets, respectively .

## 5. Hot switching protection

Always change the switch positions during receive. Never switch input or output while transmitting.

To prevent inadvertently hot switching. The ES-1A has logic that uses the PTT voltage level to inhibit switching.

This only works if the PTT connection is used .

To use the PTT connection, it must be chained. Instead of connecting the transceiver PTT directly to the linear amplifier PTT connect from the transceiver to the ES-1A and from ES-1A to the linear amplifier PTT.

The two PTT1 and PTT2 sockets on the ES-1A rear panel are internally connected through diodes to PTT - AMP. When the PTT1 or PTT2 input of the ES-1A receives a "high" voltage level (greater than a few volts, typically 12V), ES-1A is fully operational.

During transmit PTT1 or PTT2 go low and this will also pull low PTT - AMP (voltage less than 1 volt). This will inhibit the ES-1A from switching the input or the output .

### Warning:

- **The front panel switches are directly driving the LED indicators. These LED's change according to the switch position even if in transmit mode, with PTT low and ES-1A operation inhibited**
- **If the switch positions are changed during transmit, the internal relays will not update their positions until changing from transmit to receive. At that moment the relays will switch, assuming the configuration shown by the front panel switches and LED indicators.**

## 6. ALC Connections

In most cases ALC is not used .

If ALC is needed, the connections explained above refer to negative going ALC signal generated by the linear amplifier. Internally the ES-1A is distributing the negative ALC signal to both radios. ALC1 and ALC2 are connected through diodes to the middle socket ALC AMP.

See the diagram "EMTRON ES-1A Connections" at the end.

## 7. Remote Control

Typically, the antenna selector will have six coaxial cables wired to the back and many users might prefer it installed on top or behind the amplifier, making the front panel switches harder to reach.

An optional remote-control unit can be used in this case.

This is a plastic box with dimensions 82 x 54 x 30 mm, connected to the main unit by a 4-wire flat telephone cable. The standard cable length is 1 m (other lengths on request) and it allows the remote unit to be placed in front of the amplifier or transceiver, or even attached to the amplifier front panel.

To use the remote control:

- Unplug the short cable on the side of the main unit ES-1A. The rear end of the short cable needs to be unplugged, the front end can be removed or left in place (connected to the ES-1A front panel). To unplug the cable, squeeze the locking plastic tag on the RJ12 plug and pull it out.
- Plug the longer cable into the rear RJ12 jack. Make sure it clicks, locking in place. Connect the other end of the cable to the remote-control unit.

Now the ES-1A front panel is no longer operational, but on the remote control the LED's should be on and the switches are now controlling the main unit. The remote-control switches and LED's are identical to the main unit.

## 8. Specifications

Input power: 200 W maximum, 50 Ω load, non-switching

The non-active input: grounded

Output power: 3000 W maximum, 50 Ω load, non-switching

Feedback Output to Input: -83dB@50MHz, -97dB@30MHz

**ES-1ASP** version: 5000 W maximum, 50 Ω load, non-switching

SWR: Better than 1:1.05, 1 MHz to 30 MHz, Input (Radio) and Output (Antenna)

Power requirements: 12 VDC, 11 to 15 VDC range, up to 150 mA current (250 mA for ES-1ASP) Protection: changing input or output is inhibited when PTT is low (<1 V)

PTT1 and PTT2 RCA sockets produce a weak voltage of about +3.6 V. When pulled low, the current is <1 mA

ALC negative signal sent to the 2 radios via back to back diodes (if connected)

### NOTE:

PTT must be connected for this protection to work

The LED's are following the switch position even with PTT low (only the relays are inhibited, not the LED's)

Dimensions (overall): 196 x 116 x 85 mm

Weight : 0.67 kg (1.5 lb.)

Remote control available, connected to the main unit by cable

## 9. Warranty

Four-year warranty, parts and labour, except for lightning damage

## 10. DECLARATION OF CONFORMITY

### EMTRON INDUSTRIES

Sydney, NSW 2010, Australia

Tel (02)92110988

### ES-1A Radio/ Antenna Selector with Remote Control ES-lark

This product is for amateur radio use.

The undersigned declares that the above product complies with the relevant parts of the following standards:

prETS 300 684 (December 1995): Radio Equipment and Systems (RES); ElectroMagnetic Compatibility (EMC) standard for commercially available amateur radio equipment (Part 1- 8).

EN 55022: Limits and methods of measurement of radio interference characteristics of information technology equipment

EN 60950 - 1:2005 Information technology equipment - Safety - Part 1 General requirements

This Declaration of Conformity is issued under the sole responsibility of the manufacturer

---

Dan Voican

Chief Engineer

ADD COMMUNICATIONS, ABN 72006922133

# EMTRON ES-4 Connections

Feb. 2017

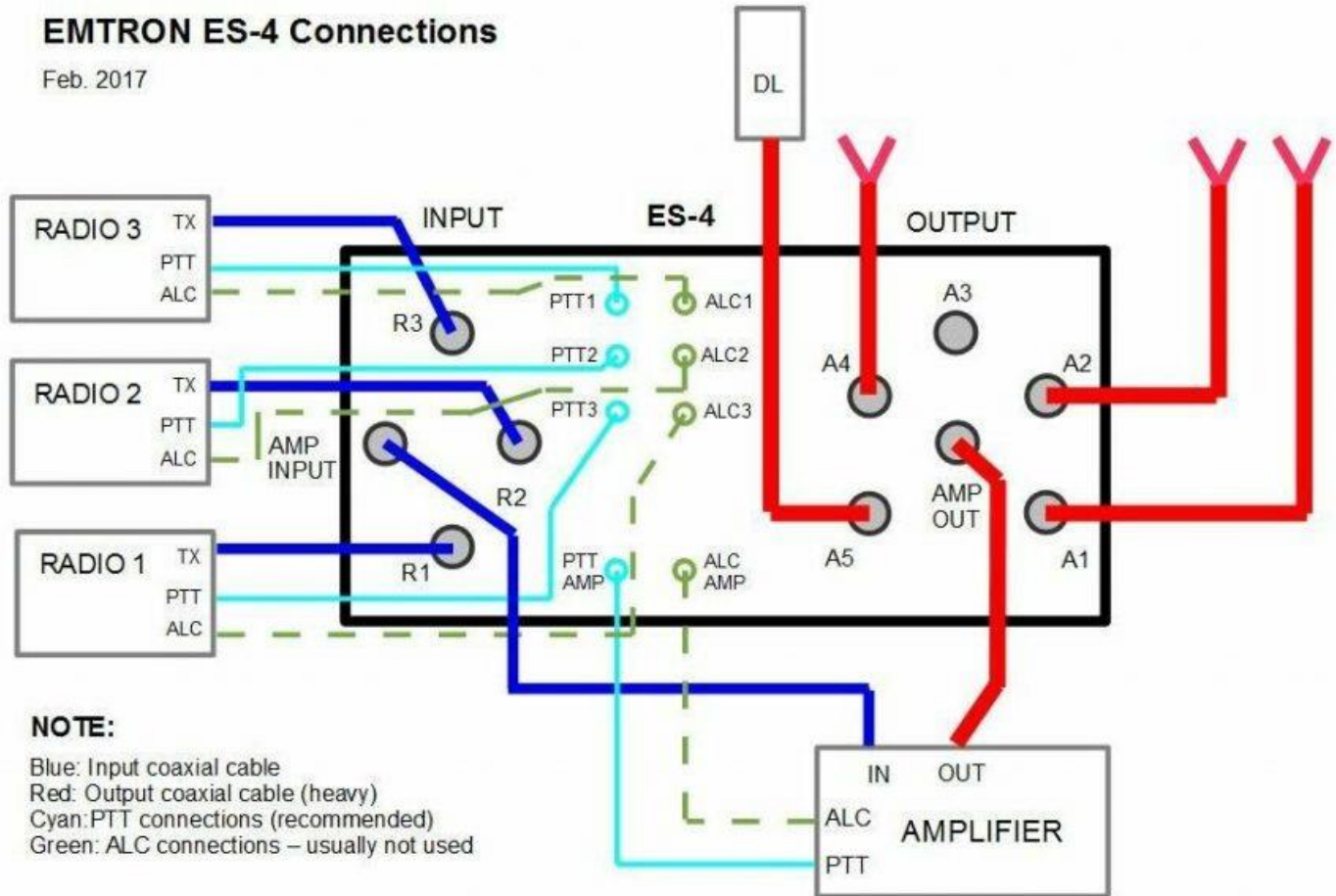

**NOTE:**

- Blue: Input coaxial cable
- Red: Output coaxial cable (heavy)
- Cyan: PTT connections (recommended)
- Green: ALC connections – usually not used

This is an example only, showing 3 radios, 3 antennas and a dummy load

